

# Resharpener Guide for YES Carbide Drills

Yes brand Carbide drill can be resharpened by CNC 5 axis machine or Universal tool grinder with our own special attachment. The below procedure is to regrind by Universal tool grinder, while follow "S" point program in case of CNC machine.

## Removal of worn section

Remove all of the worn or chipped section before regrinding.

## Regrinding drill point

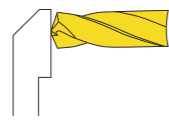

(1.1)

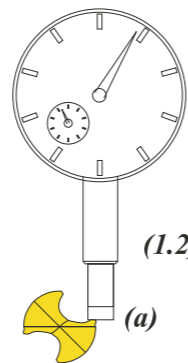

(1.2)

1. Put the drill point horizontally on the stopper. (see 1.1)
2. Set dial gauge on <a> and turn the drill to coincide central line of point. Then, tighten the collect chuck securely. (see 1.2)

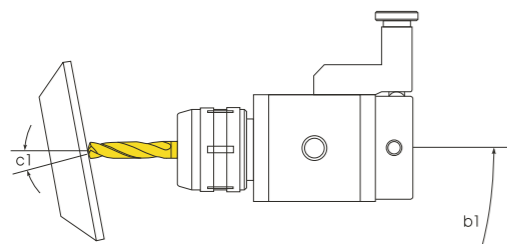

(1.3)

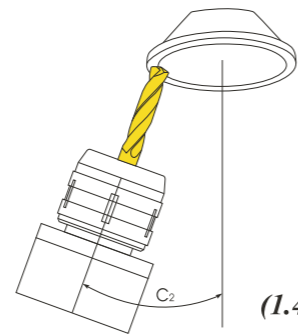

(1.4)

3. Set the cutting edge toward grinding wheel to the point angle <c1, 8°> as shown (1.3). Then, keep the angle <c2, 20°> as shown (1.4).
4. Grind the flank up and down repeatedly as shown <b1>.

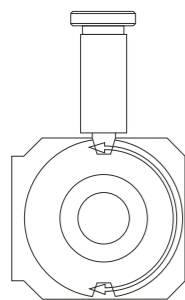

(1.5)

5. Move forward the grinding wheel and grind the cutting lips, after keeping the attachment horizontally.
6. Rotate the attachment at 180° toward <c3> and grind other cutting edge by the same procedure as NO.4, 5. (see 1.5) Make sure that both cutting lips should be equal or symmetrical.

## Web thinning

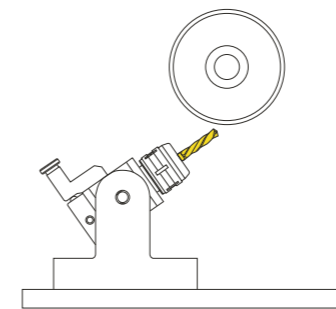

(2.1)

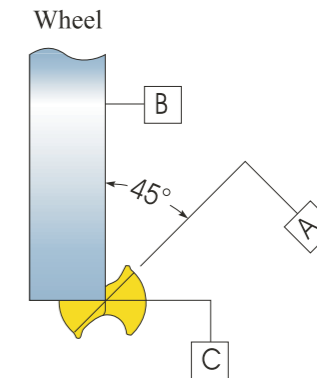

(2.2)

1. Set the drill at 30° or 35° in the drill attachment. (see 2.1) (In case of drill for AL, FC material, keep 30°, while others at 35°.)
2. Align the "B" face of wheel at center line of drill. (see 2.2)
3. Set the "B" face of wheel at 45° from central line of the drill.

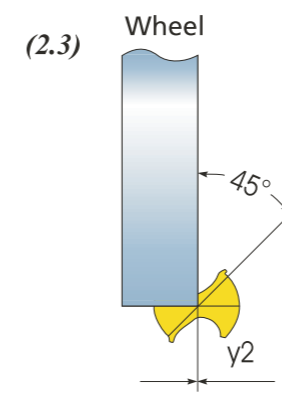

Cut 1

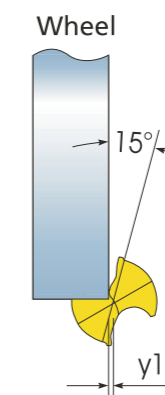

Cut 2

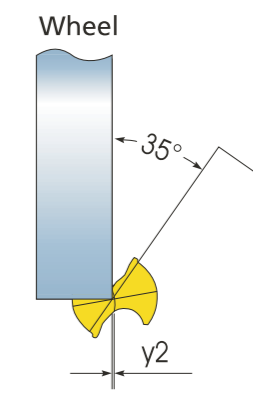

Cut 3

4. Grind as procedure <cut 1>, <cut 2>, <cut 3>. (see 2.3)
5. Rotate the attachment at 180° and grind other facet by NO.4 procedure. Note that the shape of the thinning should be such that it does not interfere with chip flow.



## Note

If you have any difficulty to regrind in your shop, you may use our factory expert service which is being serviced at reasonable cost in one week returning delivery Contact ours.