

Chamfer Holder, Metric

YCH



Model : YCH

- ▶ Specially designed to work with Solid Chamfer Drill (YCD) & Insert XCGX1102.
- ▶ Drilling and chamfering in one operation economically.
- ▶ Carbide Insert XCGX1102 has two cutting edges for economic use.
- ▶ Holder moveable back and forth to adjust cutting depth by SS bolt.

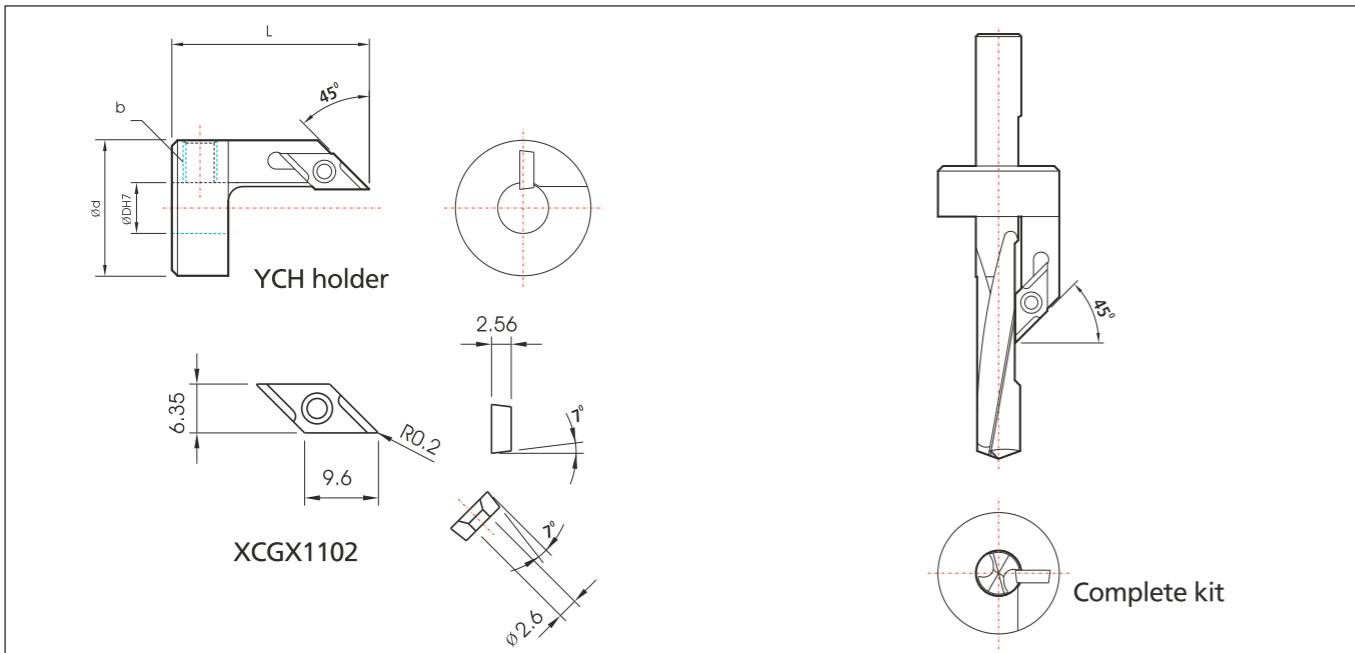

Code No.	D	d	L	Socket Screw Bolt size (b)	Applicable size range(YCD model)
YCH 060	6.0	21	29	M6 x 1.0P	YCD 051~060
YCH 070	7.0	22	32		YCD 061~070
YCH 080	8.0	23	34		YCD 071~080
YCH 090	9.0	24	35		YCD 081~090
YCH 100	10.0	25	36	M8 x 1.25P	YCD 091~100
YCH 110	11.0	26	34		YCD 101~110
YCH 120	12.0	27	36		YCD 111~120
YCH 130	13.0	28	36		YCD 121~130
YCH 140	14.0	29	38	M10 x 1.5P	YCD 131~140
YCH 150	15.0	30	39		YCD 141~150
YCH 160	16.0	31	40		YCD 151~160
YCH 170	17.0	32	42		YCD 161~170
YCH 180	18.0	33	43	M10 x 1.5P	YCD 171~180
YCH 190	19.0	34	44		YCD 181~190
YCH 200	20.0	35	45		YCD 191~200

❖ See page 61 of applicable YCD drill together with this model.

Chamfer Holder, Inch

YCH



Model : YCH

- ▶ Specially designed to work with Solid Chamfer Drill (YCD) & Insert XCGX1102.
- ▶ Drilling and chamfering in one operation economically.
- ▶ Carbide Insert XCGX1102 has two cutting edges for economic use.
- ▶ Holder moveable back and forth to adjust cutting depth by SS bolt.

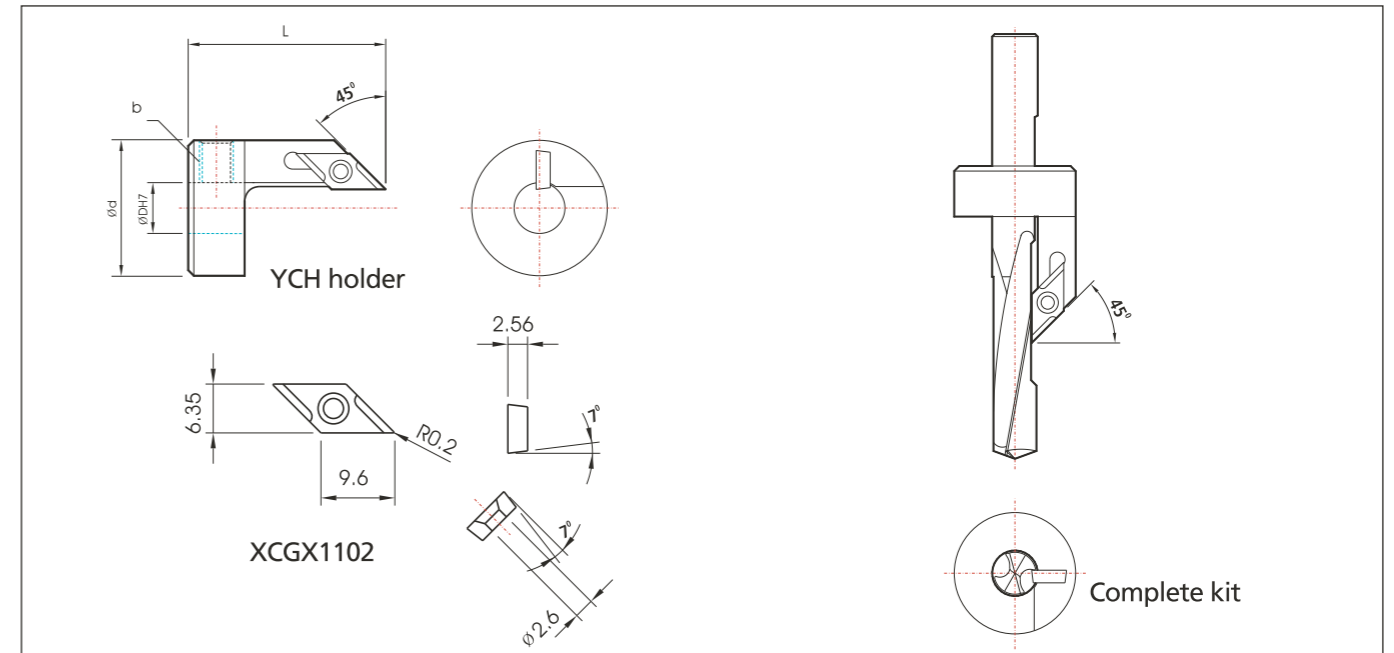

Code No.	D	d	L	Socket Screw Bolt size (b)	Applicable size range(YCD model)
YCH .2500	.2500	0.83	1.14	M6 x 1.0P	YCD .2010~.2720
YCH .3125	.3125	0.91	1.34		YCD .3125~.3320
YCH .3750	.3750	0.98	1.42	M8 x 1.25P	YCD .3680~.3906
YCH .4375	.4375	1.02	1.34		YCD .4219~.4531
YCH .5000	.5000	1.1	1.42		YCD .4844~.5156
YCH .5625	.5625	1.14	1.5	M10 x 1.5P	YCD .5312~.5781
YCH .6875	.6875	1.26	1.65		YCD .6562~.6875
YCH .7500	.7500	1.34	1.73		YCD .7656~.8125

❖ See page 63 of applicable YCD drill together with this model.